



Rev 1.00

Introducing NANOTRACE™

Innovative Pre-Insulated and Heat Traced Tubing Bundle and Sticks



INSTRUMENTATION

Designed and manufactured to meet the industry standards, safety guidelines and user expectations. Nano-Insulation (Aerogel) approved and used on the latest projects at the Norwegian Continental Shelf!

Autek AS is pleased to provide the industry with the exciting Nanotrace™ product line of Pre-Insulated Heat Traced Tubing. We are proud to represent Dekoron Unitherm – the innovative manufacture of Heat-Trace products through the past 55 years of experience. This gives us the opportunity to incorporate also the Nanotrace™ range of products to the industry – with all the features this range will offer.

Focusing: Safety, Preventing CUI (corrosion under insulation), Light Weight, Safe Installation and tight bend radius, Less Power Consumption, Reduced overall Cost etc – to name a few.

Autek provide the full program including Heater (Project/Client standard), Accessories (fitting, end connections, termination kits , JB etc.) and the Instrumentation / controls in acc. to client specifications.

Technical specification

- 30% smaller bundle diameter depending on type
- 30% to 50% less heat loss than fiberglass or mineral fiber insulation
- Hydrophobic - water is repelled by the insulation
- Halogen-free fire retardant low temperature jacket materials
- FM & Atex approvals on the complete bundle design not just the heater.
- CE and GOST-R certified
- Prevent tubing from stress corrosion cracking
- Heater (brand) in acc. to Project / Client specification and request
- Tubing material SS316, 6MO, Duplex, Super Duplex, Titanium, etc. material from NORSOK M650 approved suppliers.

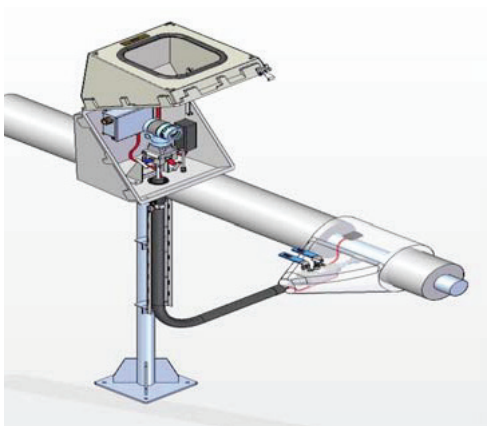

Autek provide the complete Instrument Enclosure system (plug & play) by representation of world-leading manufacturers and certified Instrument Engineers

- Design
- CAD/ 3D Drawings
- Assembly
- Testing
- Documentation / Final Documentation
- Installation at site (if applicable)

Instrument Enclosure c/w Nano Trace Heat-Trace tubing

accurate measurement
perfected from design to manufacturing



DESIGN & ASSEMBLING



ENGINEERING



INSTRUMENTATION



SERVICE

Our Expertise

Since Autek AS was founded in 1986 we have been providing the best possible service and instrumentation to the oil and gas industry. Our extensive experience and close cooperation with our customers, ensures an accurate understanding of their individual needs. Through nearly 30 years, our strategies and high level of expertise have proven to exceed the expectation and meet the requirements set by the onshore and offshore industry. Autek is ISO 9001:2008 certified and qualified by Achilles.



DESIGN & ASSEMBLING

3D design of instruments, systems and complete instrument enclosures to customers specifications



INSTRUMENTATION

Leading provider of instrumentation for the energy industry. Custody-Transfer flowmeters



ENGINEERING

Flow calculations, wake frequency calculations, documentation and complete instrument packages



SERVICE

Offshore certified engineers available for assistance and maintenance on general instrumentation and fiscal ultrasonic flowmeters

Company address Drammen:
Autek AS
Hofgaardsgate 27
3011 Drammen
Norway
Phone: +47 32219200

Company address Stavanger:
Autek AS avd. Vest
Energivegen 20
4056 Tananger
Norway
Phone: +47 4788 2027